

EWP BatCap

Patents Pending

Electronic Water Purifier

Capacitive Deionization (CDI)
Plus a Lead Acid battery Combined

Many industries are evolving to hybrid power and backup systems such as automotive and telecommunication. The existing Lithium and Nickel based technologies can't deliver power fast enough, cheap enough and be environmentally safe and recycled.

We developed the EWP capacitive deionization technology for water purification and now a variation of this makes patent pending technology available for a lead acid battery at very favorable recharge/discharge times.

How it Works

Electrodes used are made from activated carbon for the cathode and mixed with lead for the anode with an integral polymeric coating and a electrolyte gel in between. These electrodes are layered into a cell casing like a sandwich. A chemical reaction generates 2.1 VDC per cell and the mass deposited on the surface of the electrode. The charge is relational to the ionic mass absorbed onto the electrodes plus what is generated from from the chemical reaction.

There is a charge cycle and discharge cycle like normal batteries and capacitors. 80% of the re-charge is reached in minutes.

Benefits

- Simple Operation
- Much Lower cost than other technologies
- No hazardous chemicals and no recharge limits
- Small physical size-modular in design
- Quick recharge, fast cycle times

Applications

- Hybrid power in vehicles
- Backup power
- Wireless transmissions
- Solar power
- Power for electric bikes, rickshaws, e-carts

Comparison to Existing Technologies

	Pb-CDI Gel	STD Pb Acid	Li polymer ¹	Ni MH
cost	\$58	\$35	\$200	\$22
amp hr	40	40	100	7.5
Weight kg	0.73	7.7	13.72	3.4
amp hr/kg	55	5	7	2
whr/kg	656	62	87	70
\$/watt hr	0.12	0.07	0.17	0.24
volume ft ³	0.13	0.16		

Concept View

12.6 VDC Battery 160 amp hours

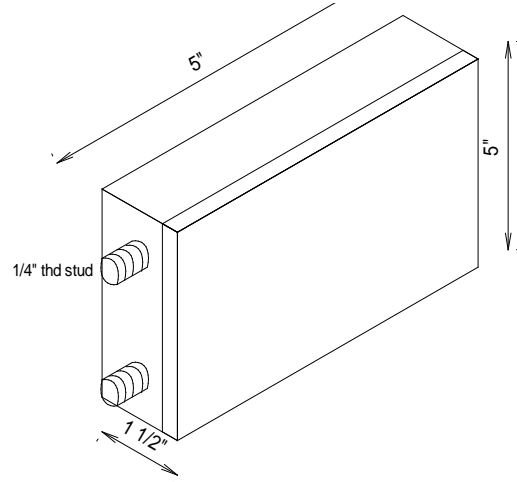

How it works

When DC voltage is applied across the electrodes, mass transfer of ions in the electrolyte solutions diffuse through a semi permeable coating onto the electrode surface.

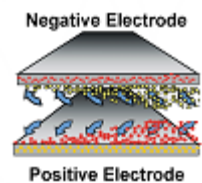

The mass deposited is proportional to the charge available. During discharge the ions release from the surface in a reversible process creating power available for use.

AQUA EWP

1326 North Trinity • San Antonio, TX 78207
Tel 210-737-8000 fax 210-737-6791
www.AquaEWP.com
Email: Aquaewp@swbell.net